

CONCRETE TOP SLAB

NOTE:
USE 2-*4 #3"
AROUND LID ASSEMBLY

**MANHOLE DETAIL
(FRAME AND LID REMOVED)**

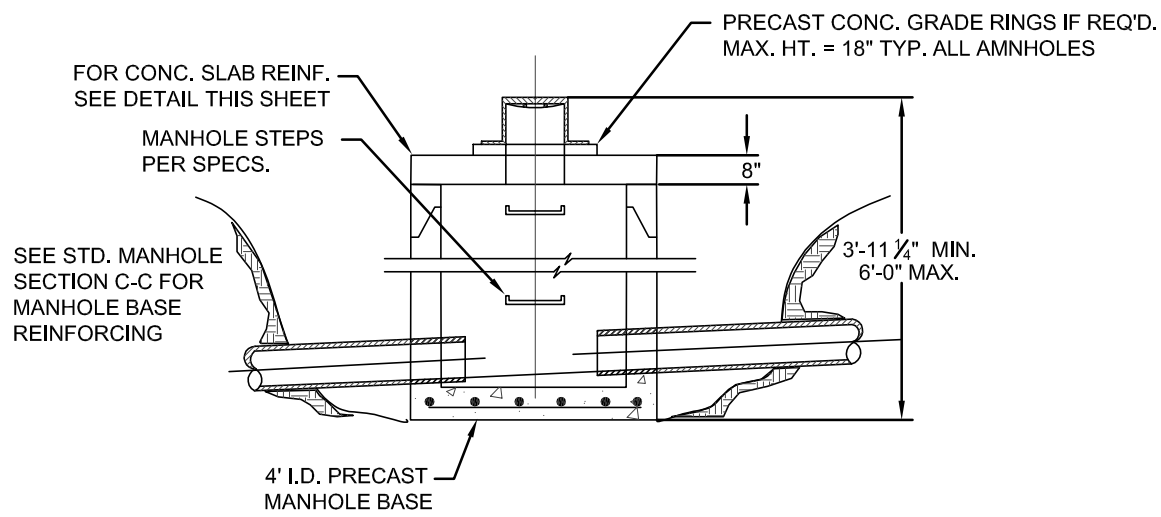

**MANHOLE WITH SLAB TOP
SECTION A-A**

**MANHOLE WITH
WITH SLAB TOP DETAIL**



BUTLER COUNTY
WATER AND SEWER

130 HIGH STREET
HAMILTON, OH 45011
TELEPHONE: 513-887-3066
FAX: 513-887-3777